

Lámpara de apoyo de distribución lumínica directa difusa. Campana construida en metacrilato blanco termo conformado. Base de aluminio repujado con recubrimiento termo convertible

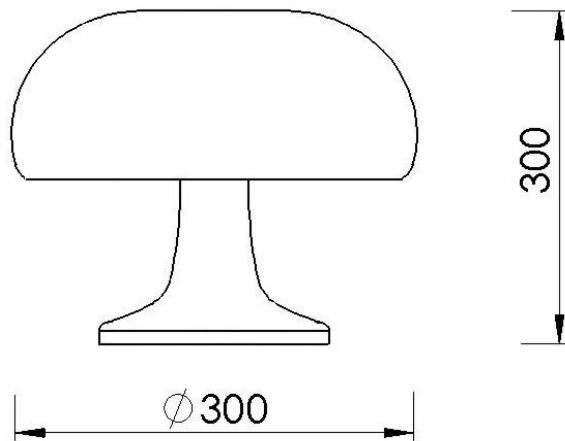

Lámpara	Potencia	Zócalo	lp
 TC-TSE	1x25w	E27	20
 A60	1x60w	E27	20